

# VOODOO LAB

## GCX Worksheet

### Feedthru and You

In this setup, the rackmounted wireless signal leaves the rack via the rear panel FEED THRU and out to a small pedalboard. The signal then returns to the rack using the GCX's GUITAR IN and continues to 4 effects placed in front of the amp.

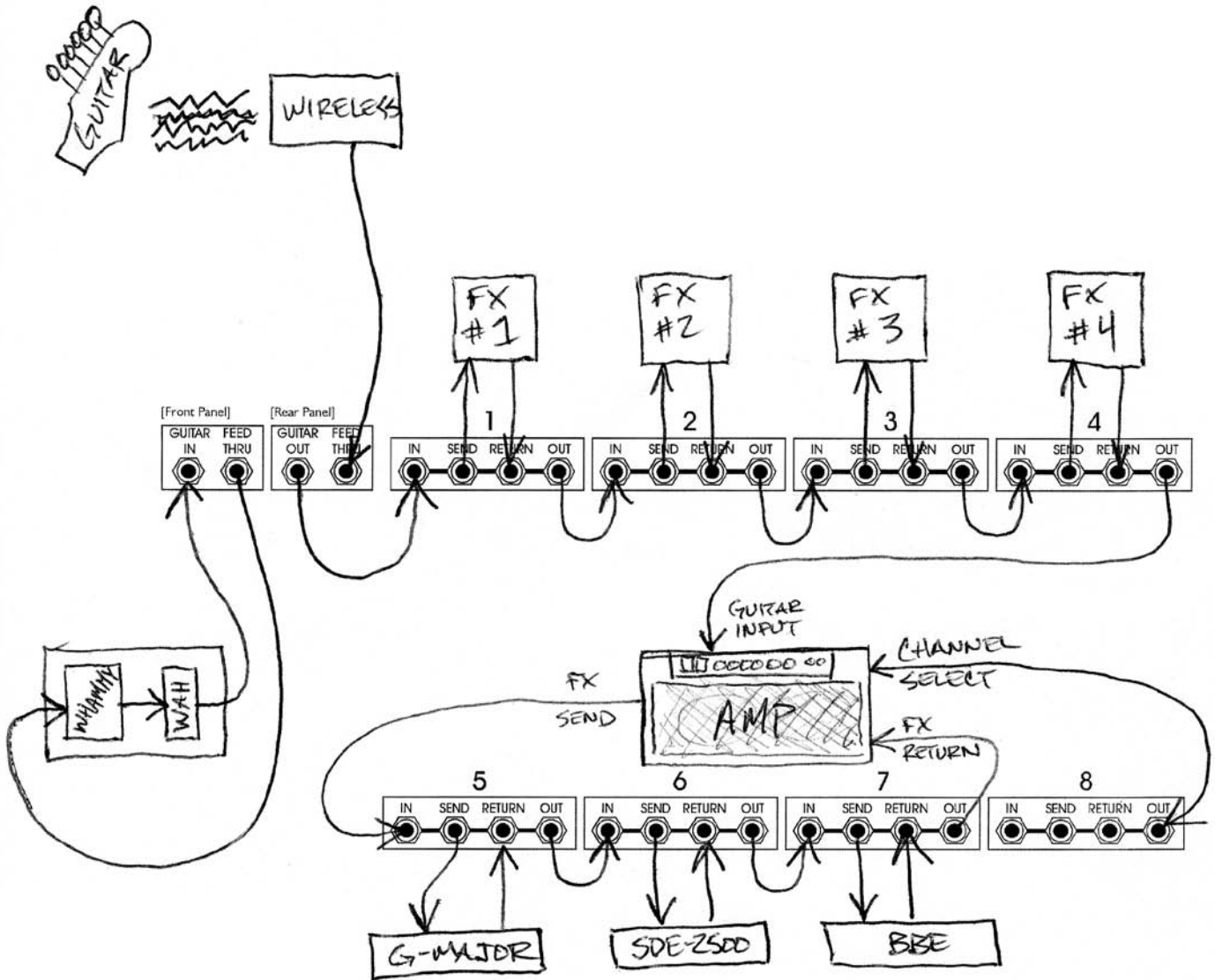

Functions:

Loop #1	FX #1	ON/OFF	Loop #5	G-MAJOR	ON/OFF
Loop #2	FX #2	ON/OFF	Loop #6	SDE-2500	ON/OFF
Loop #3	FX #3	ON/OFF	Loop #7	BBE	ON/OFF
Loop #4	FX #4	ON/OFF	Loop #8	CLEAN/DIRTY	A/B